

## EXHAUST TEMPERATURE *Installation Instructions*

Part No: SG71240  
2 inch-52mm

v20190409

### Important notes before installing:

- Installing this product to your vehicle may require an adaptor. SAAS make a large range of adaptors and installation parts, please check with your SAAS dealer for available adaptors.
- SAAS Autoline series gauges are designed for **12volt** systems **ONLY!**
- All installation work should be done by a qualified professional to avoid damage to this product.
- SAAS **RECOMMENDS** all products be tested prior to installation. This will save time and speed up the troubleshooting process if you encounter any issues.

### Wiring Guide:

Wire colour	Wire Function	Wire Connection Location
Red	Ignition 12V+	Ignition harness / Fuse box
Yellow	Illumination 12V+ ( <b>NOT</b> adjustable)	Park light circuit (do <b>NOT</b> connect to a dimmer)
Black	Ground 12V-	Vehicle body
Green	Sensor input	Exhaust sensor output (red wire of sensor)
Pink	Sensor input	Exhaust sensor output (black wire of sensor)

## Wiring Diagram *Typical Layout*

Mounting studs for U bracket.

**Fitting U bracket:** Fit supplied stud spacers to threads before using the supplied U bracket.

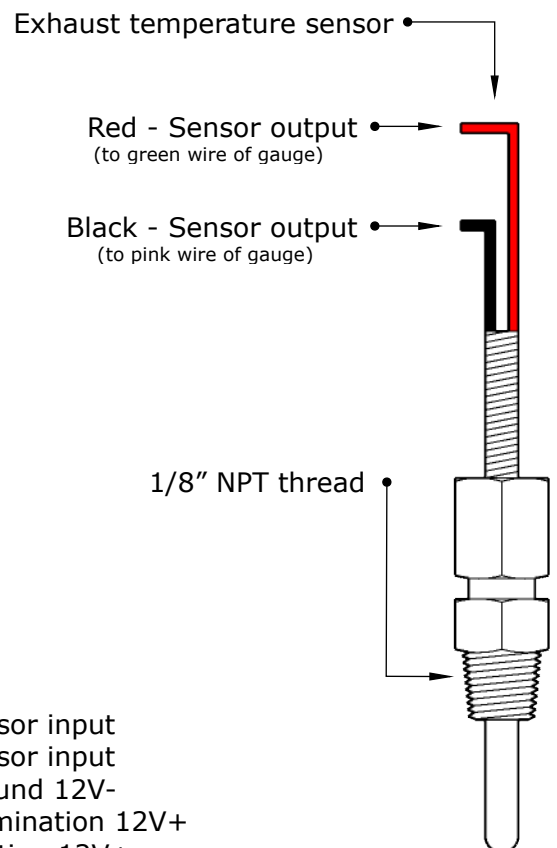
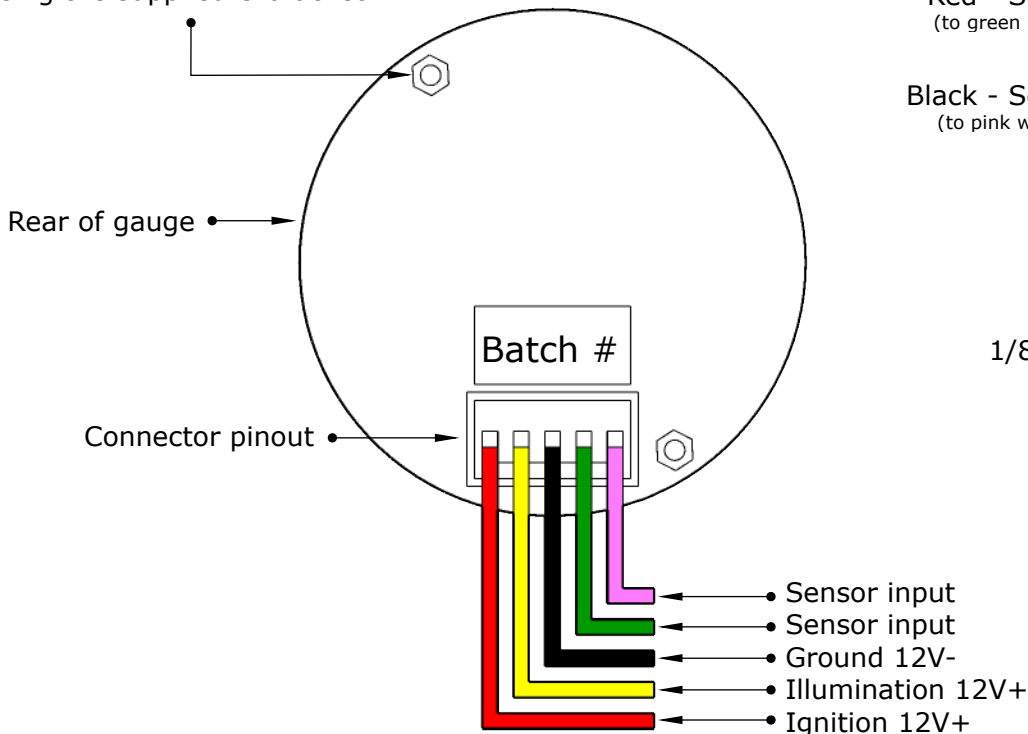

## Exhaust Sensor Installation:

### - Recommended sensor locations:

**Turbo vehicles:** Exhaust dump pipe or exhaust manifold.

### Pros & cons for exhaust dump pipe:

Easier to fit, doesn't require removal of the turbocharger, extended sensor life and slightly lower temperature readings.

### Pros & cons for exhaust manifold:

Harder to fit, exhaust manifold may need to be removed to clean out metal shavings, higher temperature readings and shorter sensor life.

**Non turbo vehicles:** Fit the sensor into the thin walled section of your exhaust manifold where all the pipes meet.

There is no right or wrong location to fit an exhaust sensor, an exhaust gauge is designed to give you a temperature reading from it's installed location that you can use as a guide to get an average running temperature. Once you have your average running temperature, you can use that to gauge weather or not you have a temperature problem.

### - Fitting the exhaust sensor:

If your exhaust has a pre existing 1/8" NPT threaded hole, just screw the exhaust sensor nut in followed by the copper retainer and then the sensor. Tighten the top nut until the sensor is locked into position and do not over tighten! A threaded adaptor or weld in bung will be required if you have a different thread size.

When using a SAAS weld in bung part# SGA1001, drill a 16mm hole in your preferred location, tap the bung in and weld around

Exhaust temperature readings are generated from the tip of the sensor, to get a good temperature reading the tip of the sensor must have a minimum depth of **10mm** in the exhaust pipe

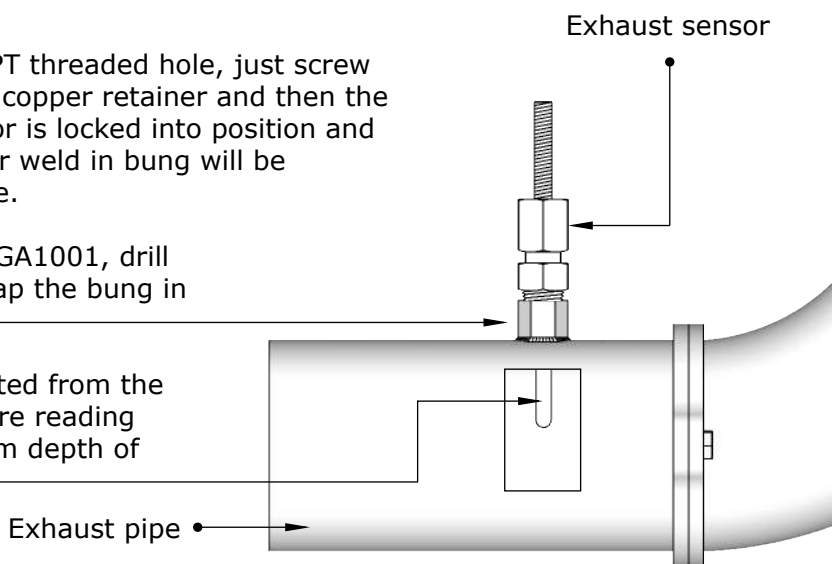

## Important Fitting Notes For Installers:

### - How to pass cables and sensors through firewalls correctly:

**Option (A):** Drill or cut a hole into a rubber grommet making sure there is enough room behind not to damage any factory cables and enough space to pass your cables and sensors through **without** any force. **DO NOT** pull on connectors when feeding through firewalls or grommets!

**Option (B):** Wrap some electrical tape around a wire coat hanger and around the connectors/ cables that you want to pass through the firewall, use some WD40 to lubricate the coat hanger so the connectors pass through the firewall grommet gently. **DO NOT** pull on connectors when feeding through firewalls or grommets!

- **WARNING:** When installing exhaust sensors, **DO NOT** allow the braided cable to twist or bend while screwing the sensor in or out of the exhaust! Over twisting or bending the cable will cause the inner cables and braided shield to break underneath the spring causing incorrect readings or no readings at all and this will **NOT** be covered under warranty!

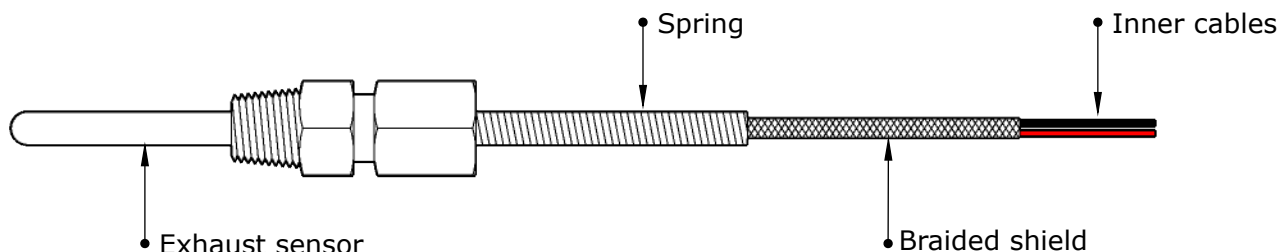

# **GAUGE INFORMATION**

## *Specifications*

Gauge and sender operating range	0°C > 900
Gauge operating voltage	8v > 18v
Exhaust temp sensor type	(K type), $\Omega$ test: 17 $\Omega$ > 21°C
Exhaust temp sensor thread size	1/8" NPT
Mounting depth required for sensor	10mm (minimum) must be in the exhaust pipe
Exhaust temp sensor dimensions	Total length 85mm, wire length 2 meters
Gauge lighting type	LED (NON DIMMABLE)
Gauge lighting colour	white
Mounting depth required for gauge	55mm (minimum)
Total depth of gauge	60mm (including bezel)
Mounting hole size for gauge	52mm

## ***Troubleshooting:***

**Please note:** If you are having problems with the installation of this product, please do not contact your retailer or SAAS until you have read **ALL** the troubleshooting notes below.

<b>Problem</b>	<b>Possible Cause</b>	<b>Solution</b>
-gauge not reading	-bad connection on gauge	-test for power at the back of the gauge
-needle jumps around	-exhaust sensor not plugged in correctly	-check for loose crimp connectors on the sensor cable and re crimp if needed
-needle goes to (MAX)	-wet sensor	-allow sensor to dry out
	-exhaust sensor cables reversed	-reverse cables
	-damaged sensor	-check if sensor is in spec with a multimeter ( <b>see above for specs</b> )
-no back lighting	-incorrect wiring	-refer to fitting instructions
	-connected to a dimmer	-refer to fitting instructions

## ***Additional Troubleshooting Notes/Tips:***

### **- How to test a Autoline exhaust gauge:**

Disconnect exhaust sensor from gauge, power up gauge, if needle goes to 900°C gauge is ok, if needle does not move from (0) check wiring to gauge.

### **- How to test a Autoline exhaust sensor:**

Disconnect exhaust sensor from gauge, use a led test light or multimeter and check for any ground signal coming through sensor cables. If ground is present in either cable then check sensor for damage or replace sensor. If no ground is present then check the  $\Omega$ ohms with a multimeter, a good sensor should read around 17 $\Omega$  @ room temp (21°C).

**For further assistance email: [tech@saasautomotive.com.au](mailto:tech@saasautomotive.com.au)**

## Contents:

In The Box	Qty	Notes	Part No.
Exhaust temperature gauge	1		
Exhaust temperature sender	1		SG21003
Wiring connector	1		SG2140
Mounting U bracket	1		SG21005
Mounting U bracket studs (M4x0.7 thread)	2		
Mounting U bracket nuts	2		
Fitting instructions	1		

## Warranty Terms & Conditions:

SAAS Automotive Pty Ltd warrants this product against defects in factory workmanship and materials for a period of twelve (12) months from the date of original purchase. This warranty applies to the first retail purchaser, is non-transferable and covers only where the product has been subjected to normal use or service. Provision of this warranty shall not apply to any SAAS Automotive product that has been used for a purpose for which it is not designed, or which has been altered in any way that would be detrimental to the performance or life of the product, or misapplication, misuse, negligence or accident. Warranty claims to the manufacturer must be transportation prepaid and accompanied with dated proof of purchase. On any part or product found to be defective after examination by SAAS Automotive Pty Ltd, SAAS Automotive Pty Ltd will only repair or replace the merchandise through the original selling dealer or on a direct basis. SAAS Automotive Pty Ltd assumes no responsibility for diagnosis, removal and/or installation labour, loss of vehicle use, loss of time, inconvenience or any other consequential expenses. The warranties herein are in lieu of any other expressed or implied warranties, including any implied warranty of suitability, and any other obligation on the part of SAAS Automotive Pty Ltd, or the selling dealer.

**For further assistance email: [tech@saasautomotive.com.au](mailto:tech@saasautomotive.com.au)**



SINCE 1954

SAAS Automotive PTY LTD  
25 Metrolink Circuit West, Campbellfield,  
Victoria 3061 Australia

ABN: 48166279670  
ACN: 166279670

Phone: +61 3 9930 0100  
Fax: +61 3 8339 2270  
Email: [tech@saasautomotive.com.au](mailto:tech@saasautomotive.com.au)  
Web: [www.shopsaas.com](http://www.shopsaas.com)