



OIL PRESSURE

Part No: SG32230
2 inch-52mm

Installation Instructions

v20230508

Important notes before installing:

- Installing this product to your vehicle may require an adaptor. SAAS offer a large range of adaptors and installation parts; please check with your SAAS dealer for available adaptors.
- SAAS Muscle series gauges are designed for **12volt** systems **ONLY!**
- All installation work should be done by a qualified professional to avoid damage to this product.
- SAAS **RECOMMENDS** all products be tested prior to installation. This will save time and speed up the troubleshooting process if you encounter any issues.

- **BEFORE** installing, please check our website (shopsaas.com) for the latest fitting instructions. If the top left corner (**v**) number is different to website, please use instructions from website.

Wiring Guide:

Wire colour	Wire Function	Wire Connection Location
Black	Ground 12V-	Vehicle body
Yellow	Park lights 12V+	Park light circuit (do NOT connect to a dimmer)
White	Battery 12V+	Ignition harness / Fuse box
Red	Ignition 12V+	Ignition harness / Fuse box

Wiring Diagram Typical Layout

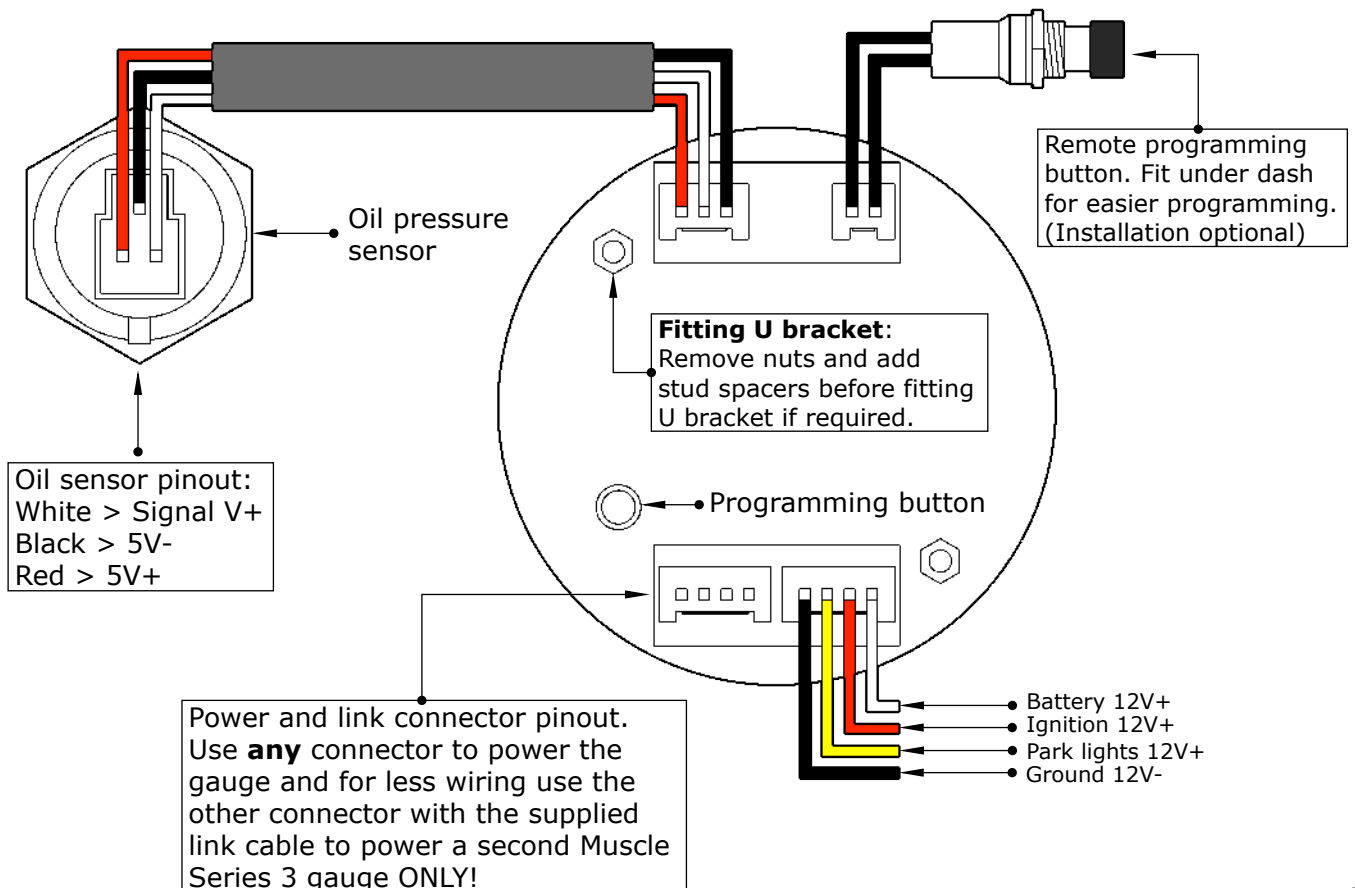

User Functions:

Note: Use the remote programming button or the button on the back of the gauge to set the below functions.

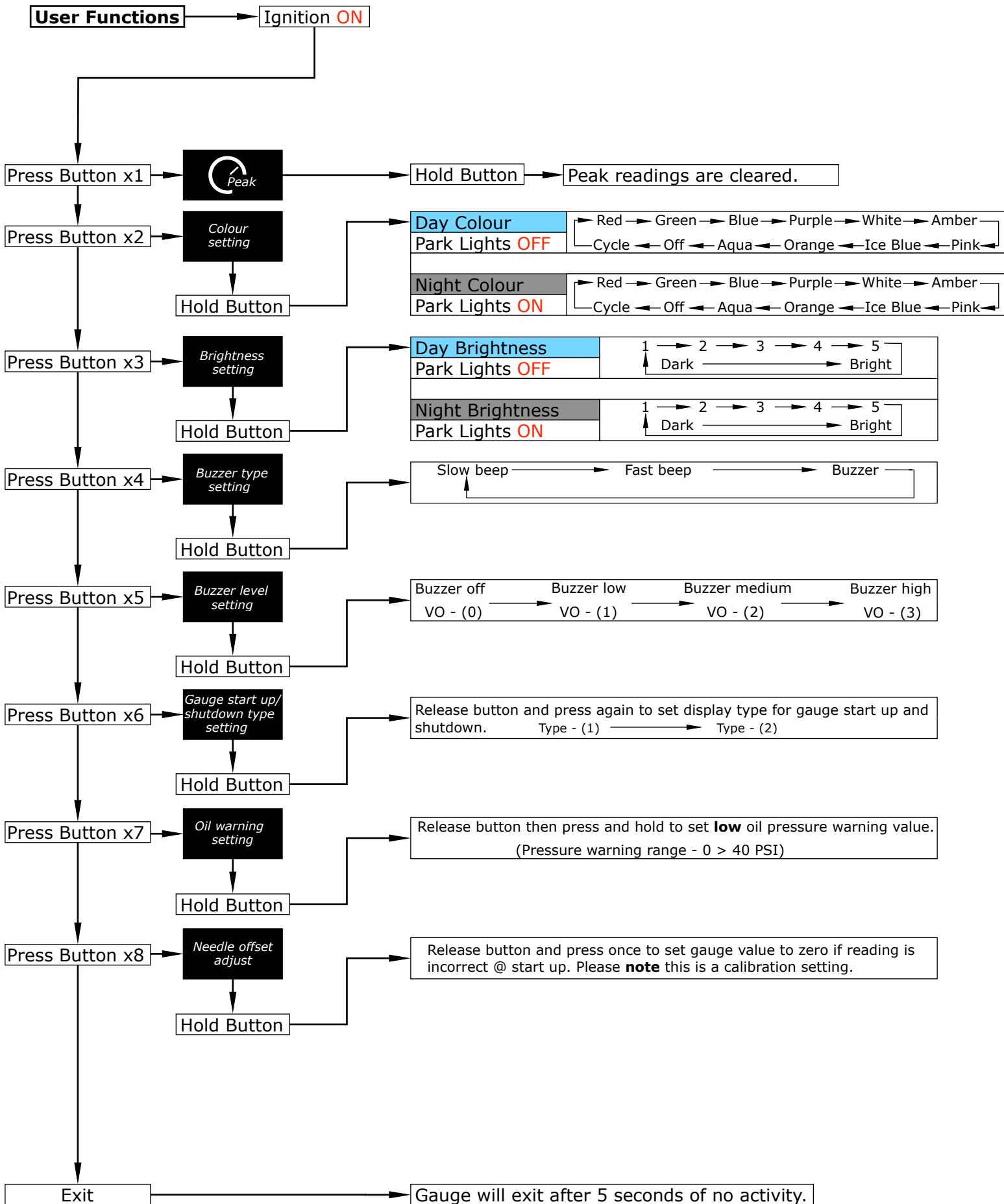

Oil Pressure Sensor Installation:

- **Recommended sensor locations:** Engine block, oil pump/filter housing, factory oil switch location.

- **Fitting the oil pressure sensor:**

There are a two ways to fit an oil pressure sensor to your engine. One way is to use a oil filter sandwich plate and the other is to use a tee adaptor.

- **Oil Filter Sandwich Plate (Recommended):**

The diagram to the right shows how a sandwich plate is fitted and in most cases is the quickest.

- **Tee Adaptor:**

A tee adaptor allows the factory oil switch and a second oil pressure sensor to be fitted in the same location.

Tee adaptors can be harder to fit due to the lack of space on some engines. If the factory oil switch is in a hard to reach position, then it is recommended that you fit the SAAS oil pressure sender in a remote location so it will be much easier to get to for servicing and testing.

- **Tip:** Braided turbo feed line works great as an extension and can also be used on oil filter sandwich plates for vehicles with compact engine bays.

- **Caution:** Removal of the factory oil switch is not recommended! Modern vehicles need the factory oil switch to operate correctly and will set off dash warning lights if they are removed.

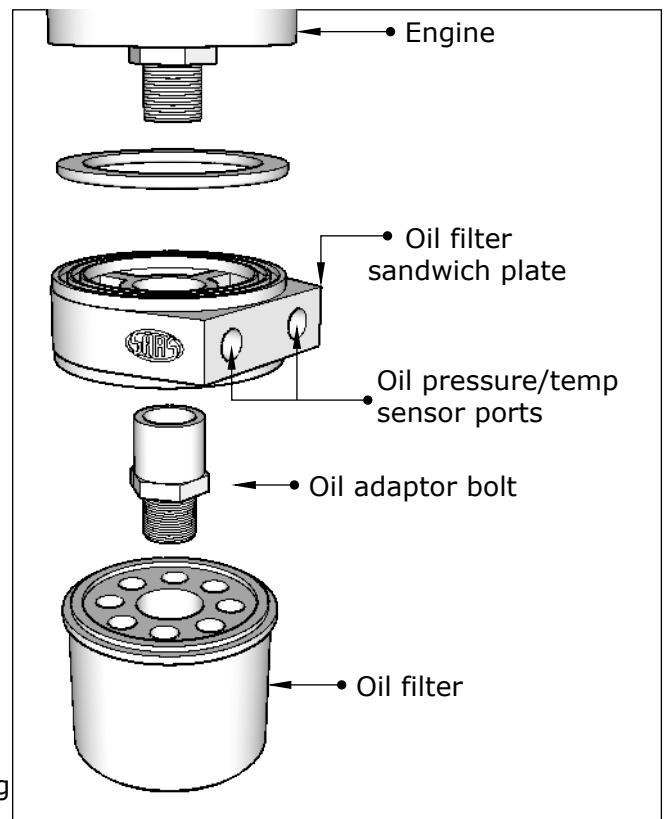

GAUGE INFORMATION

Specifications

Gauge operating range	0 > 140 PSI
Gauge operating voltage	8v > 18v
Oil sensor operating range	0 > 140 PSI
Oil sensor operating scale	0.5v @ 0 PSI, 0.9v @ 15 PSI
Oil sensor cable length	3 metre
Oil sensor thread size	1/8" NPT
Gauge lighting type	10 colour LED with 5 levels of brightness
Gauge lighting colours	red - green - blue - purple - white - amber - pink - ice blue - orange - aqua - OFF - cycle mode
Gauge power harness length	1 metre
Gauge link harness length	300mm
Mounting depth required for gauge	45mm (minimum)
Total depth of gauge	50mm (including bezel)
Mounting hole size for gauge	52mm

For further assistance email: tech@saasautomotive.com.au

Troubleshooting:

Please note: If you are having problems with the installation of this product, please do not contact your retailer or SAAS until you have read **ALL** the troubleshooting notes below.

Problem	Possible Cause	Solution
-readings jump around	-damaged or blocked sensor	-check sensor for damage or blockage
-not reading oil pressure	-sensor not plugged in correctly -damaged sensor	-check connector on gauge and sensor -test sensor using a multimeter, a good sensor should read: 0.5v @ 0 PSI or 0.9v @ 15 PSI
-gauge beeps and flashes randomly	-warning function activated	-adjust warning settings accordingly

Contents:

In The Box	Qty	Notes	Part No.
Oil pressure gauge	1		
Oil pressure sensor and 3 pin gauge harness	1		SG91002
Remote programming button	1		SG4106
Gauge power connector	1		SG5100
Gauge link connector	1		SG9101
Mounting U bracket with studs, nuts and washers	1	(M4x0.7 thread)	SG61005
Fitting instructions	1		

Warranty Terms & Conditions:

SAAS Automotive Pty Ltd warrants this product against defects in factory workmanship and materials for a period of twelve (12) months from the date of original purchase. This warranty applies to the first retail purchaser, is non-transferable and covers only where the product has been subjected to normal use or service. Provision of this warranty shall not apply to any SAAS Automotive product that has been used for a purpose for which it is not designed, or which has been altered in any way that would be detrimental to the performance or life of the product, or misapplication, misuse, negligence or accident. Warranty claims to the manufacturer must be transportation prepaid and accompanied with dated proof of purchase. On any part or product found to be defective after examination by SAAS Automotive Pty Ltd, SAAS Automotive Pty Ltd will only repair or replace the merchandise through the original selling dealer or on a direct basis. SAAS Automotive Pty Ltd assumes no responsibility for diagnosis, removal and/or installation labour, loss of vehicle use, loss of time, inconvenience or any other consequential expenses. The warranties herein are in lieu of any other expressed or implied warranties, including any implied warranty of suitability, and any other obligation on the part of SAAS Automotive Pty Ltd, or the selling dealer.

For further assistance email: tech@saasautomotive.com.au



SINCE 1954

SAAS Automotive PTY LTD
25 Metrolink Circuit West, Campbellfield,
Victoria 3061 Australia
ABN: 48166279670
ACN: 166279670
Phone: +61 3 9930 0100
Fax: +61 3 8339 2270
Email: tech@saasautomotive.com.au
Web: www.shopsaas.com