



MUSCLE 3 SERIES



FUEL LEVEL

Part No: SG32290
2 inch-52mm

Installation Instructions

v20230508

Important notes before installing:

- Installing this product to your vehicle may require an adaptor. SAAS offer a large range of adaptors and installation parts; please check with your SAAS dealer for available adaptors.
- SAAS Muscle series gauges are designed for **12volt** systems **ONLY!**
- All installation work should be done by a qualified professional to avoid damage to this product.
- SAAS **RECOMMENDS** all products be tested prior to installation. This will save time and speed up the troubleshooting process if you encounter any issues.

- **BEFORE** installing, please check our website (shopsaas.com) for the latest fitting instructions. If the top left corner (**v**) number is different to website, please use instructions from website.

Wiring Guide:

Wire colour	Wire Function	Wire Connection Location
Black	Ground 12V-	Vehicle body
Yellow	Park lights 12V+	Park light circuit (do NOT connect to a dimmer)
White	Battery 12V+	Ignition harness / Fuse box
Red	Ignition 12V+	Ignition harness / Fuse box

Wiring Diagram

Typical Layout

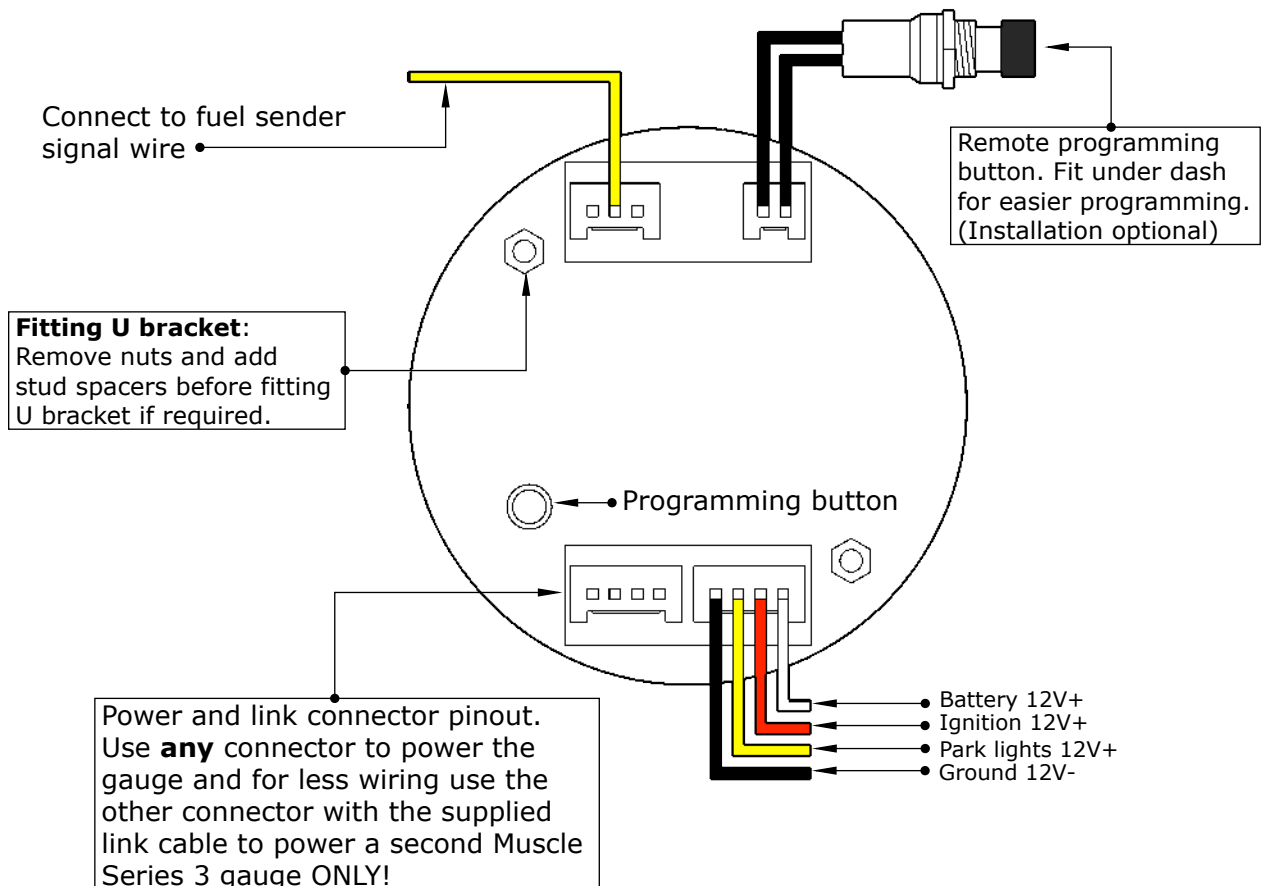

User Functions:

Note: Use the remote programming button or the button on the back of the gauge to set the below functions.

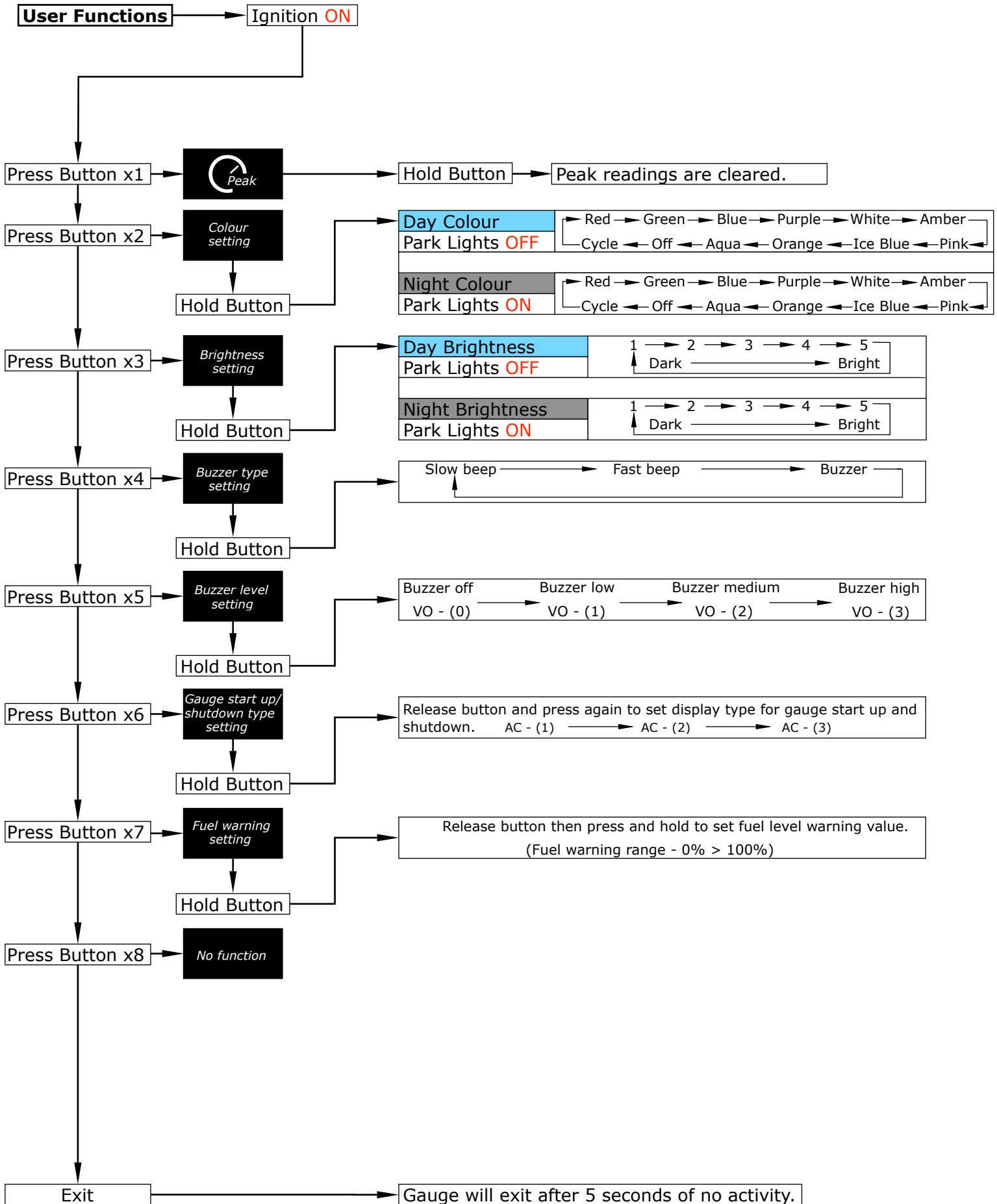

Sender Setup:

- Use the chart below to find a preset that suits your application. There are 9 presets available.

- Sender setup mode:

- Turn ignition on.
- Press and hold programming button for 4 seconds then release.
- Press button again to change preset number from chart below.
- Once you have selected a preset, wait 4 seconds for the gauge to exit set up mode.

Preset	Manufacturer	Ω scale									
1	Ford (Pre - 1989)	Dial	Empty	-	1/4	-	1/2	-	3/4	-	Full
	Chrysler	Ω	73	65.1	57.3	49.4	41.5	33.6	25.8	17.9	10
2	Ford	Dial	Empty	-	1/4	-	1/2	-	3/4	-	Full
	(1989 - Present)	Ω	16	33.7	51.5	69.2	87	104.7	122.5	140.2	158
3	GM (Pre - 1965)	Dial	Empty	-	1/4	-	1/2	-	3/4	-	Full
		Ω	0	3.8	7.5	11.3	15	18.8	22.5	26.3	30
4	GM	Dial	Empty	-	1/4	-	1/2	-	3/4	-	Full
	(1965 - Present)	Ω	0	11.3	22.5	33.8	45	56.3	67.5	78.8	90
5	Auto Meter Sender	Dial	Empty	-	1/4	-	1/2	-	3/4	-	Full
		Ω	240	206.3	172.5	138.8	105	87	69	51	33
6	Mitsubishi	Dial	Empty	-	1/4	-	1/2	-	3/4	-	Full
	Honda	Ω	107.5	94.9	82.4	69.8	57.3	44.7	32.1	19.6	7
7	Honda	Dial	Empty	-	1/4	-	1/2	-	3/4	-	Full
	(2001 - Present)	Ω	131	116.1	101.3	86.4	71.5	56.6	41.8	26.9	12
8	Japanese Sender	Dial	Empty	-	1/4	-	1/2	-	3/4	-	Full
		Ω	0	15	30	45	60	75	90	105	120
9	SAAS Sender	Dial	Empty	-	1/4	-	1/2	-	3/4	-	Full
	(sold separately)	Ω	10	31.3	52.5	73.8	95	116.3	137.5	158.8	180

Installation Tips:

- For other vehicles and applications not listed:

- **Option 1:** Remove fuel sender from tank (if possible) and measure the resistance @ Empty > Half > Full. Pick a preset from the above chart that has the closest values and use that preset.

- **Option 2:** Fill the fuel tank to its maximum, disconnect the fuel sender wire and measure the resistance at the sender, pick a preset from the above chart with the closest (Full) value and try that preset. If this method does not work then choose the next closest preset and try again.

Troubleshooting:

Please note: If you are having problems with the installation of this product, please do not contact your retailer or SAAS until you have read **ALL** the troubleshooting notes below.

Problem	Possible Cause	Solution
-gauge reading is out	-wrong preset selected	-check preset chart for correct setting
-no reading	-incorrect wiring	-refer to fitting instructions
	-wrong preset selected	-check preset chart for correct setting
-gauge beeps and flashes randomly	-warning function activated	-adjust warning settings accordingly

GAUGE INFORMATION

Specifications

Gauge operating range	E > F (0-100%)
Gauge operating voltage	8v > 18v
Gauge lighting type	10 colour LED with 5 levels of brightness
Gauge lighting colours	red - green - blue - purple - white - amber - pink - ice blue - orange - aqua - OFF - cycle mode
Fuel sender harness length	2 metre
Gauge power harness length	1 metre
Gauge link harness length	300mm
Mounting depth required for gauge	45mm (minimum)
Total depth of gauge	50mm (including bezel)
Mounting hole size for gauge	52mm

Contents:

In The Box	Qty	Notes	Part No.
Fuel gauge	1		
Remote programming button	1		SG4106
Fuel sender 3 pin harness	1		SG4107
			SG5100
Gauge power connector	1		SG9101
Gauge link connector	1		SG61005
Mounting U bracket with studs, nuts and washers	1	(M4x0.7 thread)	
Fitting instructions	1		

Warranty Terms & Conditions:

SAAS Automotive Pty Ltd warrants this product against defects in factory workmanship and materials for a period of twelve (**12**) months from the date of original purchase. This warranty applies to the first retail purchaser, is non-transferable and covers only where the product has been subjected to normal use or service. Provision of this warranty shall not apply to any SAAS Automotive product that has been used for a purpose for which it is not designed, or which has been altered in any way that would be detrimental to the performance or life of the product, or misapplication, misuse, negligence or accident. Warranty claims to the manufacturer must be transportation prepaid and accompanied with dated proof of purchase. On any part or product found to be defective after examination by SAAS Automotive Pty Ltd, SAAS Automotive Pty Ltd will only repair or replace the merchandise through the original selling dealer or on a direct basis. SAAS Automotive Pty Ltd assumes no responsibility for diagnosis, removal and/or installation labour, loss of vehicle use, loss of time, inconvenience or any other consequential expenses. The warranties herein are in lieu of any other expressed or implied warranties, including any implied warranty of suitability, and any other obligation on the part of SAAS Automotive Pty Ltd, or the selling dealer.

For further assistance email: tech@saasautomotive.com.au



SINCE 1954

SAAS Automotive PTY LTD
25 Metrolink Circuit West, Campbellfield,
Victoria 3061 Australia
ABN: 48166279670
ACN: 166279670
Phone: +61 3 9930 0100
Fax: +61 3 8339 2270
Email: tech@saasautomotive.com.au
Web: www.shopsaas.com