



Part Number: SGA1006

Oil Pressure Adaptor for V6 Commodore

- Allows the use of after-market gauge senders to be used along with factory OEM sender. (Factory senders must be retained as this will affect the vehicles ECU.) If not installed:
- VZ V6 Series 2 (VE Engine)
- VE V6
- M16 X 2mm Thread - 1/8 NPT Auxiliary Ports

Instructions

Located on the side of the engine block, carefully remove the factory sender.

Once removed begin by carefully screwing down the SAAS adaptor by hand. It is **IMPORTANT** the auxiliary port is facing the correct position so the after-market sender can be fitted.

Once the adaptor is in position tighten with a spanner (do not to over-tighten as this could strip the thread).

Screw in the after-market gauge sender.

SAAS recommends you run the engine and check for oil leaks.

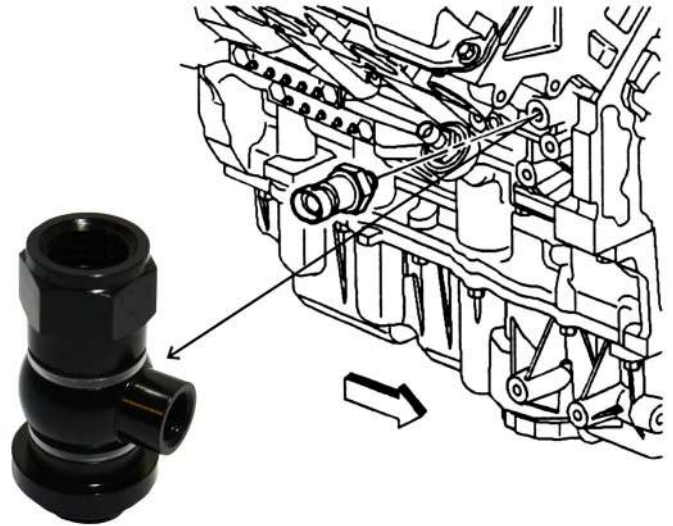

NOTE: Please do not over-tighten the adaptor as this may cause the nylon washer to distort. Doing this could then cause the adaptor to leak.